

A
B
C

SECTION **PB**

PARKING BRAKE SYSTEM

CONTENTS

PRECAUTION 2	ON-VEHICLE REPAIR 7	PB
PRECAUTIONS 2	PARKING BRAKE CONTROL 7	
Precaution for Supplemental Restraint System (SRS) "AIR BAG" and "SEAT BELT PRE-TENSIONER"2	Exploded View 7	G
	Removal and Installation 7	
PREPARATION 3	PARKING BRAKE SHOE 9	
	Exploded View 9	H
PREPARATION 3	Removal and Installation 9	
Commercial Service Tool3	SERVICE DATA AND SPECIFICATIONS (SDS)11	I
ON-VEHICLE MAINTENANCE 4	SERVICE DATA AND SPECIFICATIONS (SDS)11	
PARKING BRAKE SYSTEM 4	Parking Drum Brake11	J
Inspection4	Parking Brake Control11	
Adjustment4		K
PARKING BRAKE SHOE 6		
Inspection6		L

PRECAUTIONS

< PRECAUTION >

PRECAUTION

PRECAUTIONS

Precaution for Supplemental Restraint System (SRS) "AIR BAG" and "SEAT BELT PRE-TENSIONER"

INFOID:000000005796907

The Supplemental Restraint System such as "AIR BAG" and "SEAT BELT PRE-TENSIONER", used along with a front seat belt, helps to reduce the risk or severity of injury to the driver and front passenger for certain types of collision. This system includes seat belt switch inputs and dual stage front air bag modules. The SRS system uses the seat belt switches to determine the front air bag deployment, and may only deploy one front air bag, depending on the severity of a collision and whether the front occupants are belted or unbelted. Information necessary to service the system safely is included in the SR and SB section of this Service Manual.

WARNING:

- To avoid rendering the SRS inoperative, which could increase the risk of personal injury or death in the event of a collision which would result in air bag inflation, all maintenance must be performed by an authorized NISSAN/INFINITI dealer.
- Improper maintenance, including incorrect removal and installation of the SRS, can lead to personal injury caused by unintentional activation of the system. For removal of Spiral Cable and Air Bag Module, see the SR section.
- Do not use electrical test equipment on any circuit related to the SRS unless instructed to in this Service Manual. SRS wiring harnesses can be identified by yellow and/or orange harnesses or harness connectors.

PRECAUTIONS WHEN USING POWER TOOLS (AIR OR ELECTRIC) AND HAMMERS

WARNING:

- When working near the Airbag Diagnosis Sensor Unit or other Airbag System sensors with the Ignition ON or engine running, DO NOT use air or electric power tools or strike near the sensor(s) with a hammer. Heavy vibration could activate the sensor(s) and deploy the air bag(s), possibly causing serious injury.
- When using air or electric power tools or hammers, always switch the Ignition OFF, disconnect the battery, and wait at least 3 minutes before performing any service.

PREPARATION



< PREPARATION >

PREPARATION

PREPARATION

Commercial Service Tool

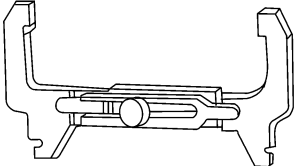
INFOID:000000005440594

(Kent-Moore No.) Tool name		Description
(J-21177-A) Brake drum clearance gauge	 <p style="text-align: center;">WFIA0167E</p>	Measuring rear rotor drum to parking brake shoe clearance
Power tool	 <p style="text-align: center;">PIIB1407E</p>	Removing bolts and nuts

A
B
C
D
E
PB
G
H
I
J
K
L
M
N
O
P

PARKING BRAKE SYSTEM

< ON-VEHICLE MAINTENANCE >

ON-VEHICLE MAINTENANCE

PARKING BRAKE SYSTEM

Inspection

INFOID:000000005440595

PEDAL STROKE

- Operate parking brake pedal with a force of 196 N (20 kg-f, 44 lb-f), make sure pedal stroke is within the specified number of notches. (Check it by listening and counting ratchet clicks.)

INSPECT COMPONENTS

- Check control device for wear or other damage. Replace if necessary.
- Check wires for wear or damage. Replace if necessary.
- Check warning lamp and switch. Replace if necessary.
- Check parts at each connecting position and if found deformed or damaged, replace as necessary.
- Check if the parking brake pedal stroke is within specification. Refer to [PB-4, "Adjustment"](#).

Adjustment

INFOID:000000005440596

ADJUSTMENT

1. Remove rear wheel and tires.
2. Insert a deep socket wrench onto adjusting nut. Rotate adjusting nut to fully loosen cable, and then release parking brake pedal.
3. Secure disc rotor to hub using wheel nut so as not to tilt disc rotor.

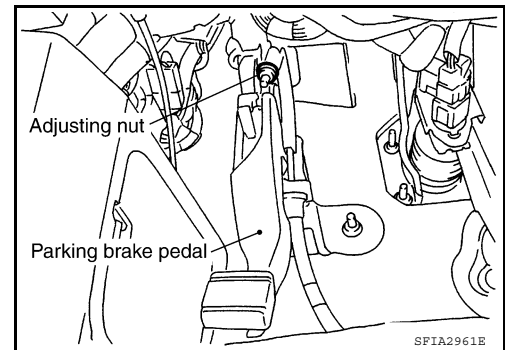

4. Remove adjuster hole plug installed on the disc rotor. Turn the adjuster in direction (A) using a suitable tool or a flat-bladed screwdriver as shown, until disc rotor is locked. Turn the adjuster in the opposite direction by 5 or 6 notches after locking.
5. Rotate disc rotor to make sure that there is no drag. Install the adjuster hole plug.
6. Adjust parking brake cable with the following procedure:
 - a. Rotate the adjusting nut to adjust parking brake pedal operating force to 490 N (50 kg-f, 110 lb-f) just before a full pedal stroke of 201.7 mm (7.94 in).
 - b. When replacing parking brake cable, operate parking brake pedal 10 or more times with a full stroke of 201.7 mm (7.94 in).
 - c. Release the parking brake pedal and rotate the disc rotor to make sure that there is no drag.
 - d. Rotate the adjusting nut to adjusting the parking brake pedal force to 196 N (20 kg-f, 44 lb-f) when the parking brake pedal stroke is within the specified number of notches. Check it by listening and counting the ratchet clicks. Operate parking brake pedal 10 or more times with a full stroke of 194.3 mm (7.6 in).

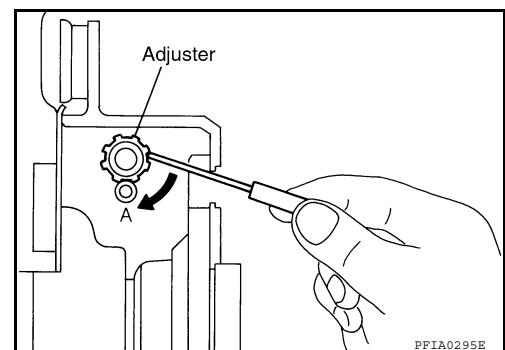

Pedal stroke number of notches : Refer to [PB-11, "Parking Brake Control"](#).

PARKING BRAKE SYSTEM

< ON-VEHICLE MAINTENANCE >

- e. After adjustment, check that there is no drag with the parking brake pedal is being released. If drag exists, perform the following:
- Remove the rear disc rotor, refer to [BR-34. "BRAKE CALIPER ASSEMBLY : Removal and Installation"](#). Verify the toggle lever returns to stopper when the parking brake pedal is released.
 - If toggle lever does not return to stopper, loosen adjuster nut.
 - Install rear disc rotor and adjust shoe clearance. Refer to [BR-34. "BRAKE CALIPER ASSEMBLY : Removal and Installation"](#).
7. Install rear wheels and tires. Refer to [WT-60. "Adjustment"](#).

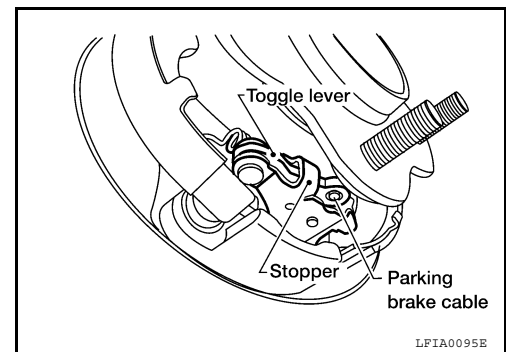

A
B
C
D
E
PB
G
H
I
J
K
L
M
N
O
P

PARKING BRAKE SHOE

< ON-VEHICLE MAINTENANCE >

PARKING BRAKE SHOE

Inspection

INFOID:000000005440597

LINING THICKNESS INSPECTION

- Check thickness of lining.

Standard thickness (new) (A) : Refer to [PB-11, "Parking Drum Brake"](#).

Wear limit thickness (A) : Refer to [PB-11, "Parking Drum Brake"](#).

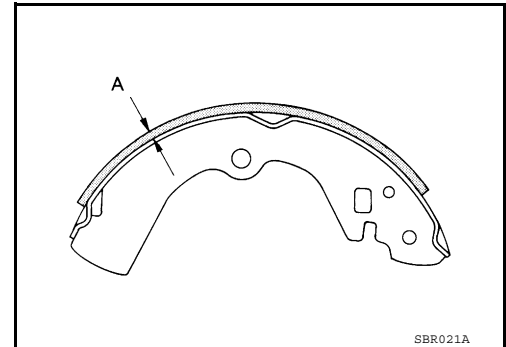

DRUM INNER DIAMETER INSPECTION

- Check inner diameter of drum in rear disc rotor.

Standard inner diameter (new) : Refer to [PB-11, "Parking Drum Brake"](#).

Wear limit of inner diameter : Refer to [PB-11, "Parking Drum Brake"](#).

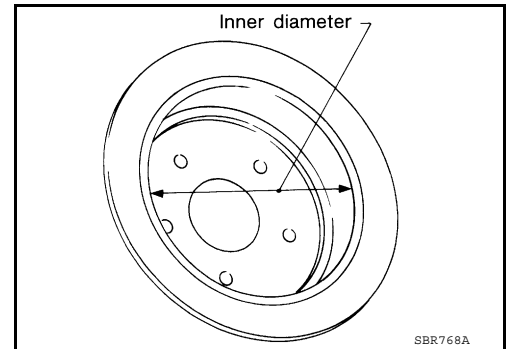

OTHER INSPECTIONS

- Check the following:
 - Lining for excessive wear, damage, and peeling.
 - Shoe sliding surface for excessive wear and damage.
 - Anti-rattle pin for excessive wear and corrosion.
 - Return spring for sagging.
- Make sure that adjuster moves smoothly.
- Visually check the inside of drum for excessive wear, cracks, and damage.
- Replace with new parts as necessary.

PARKING BRAKE CONTROL

< ON-VEHICLE REPAIR >

ON-VEHICLE REPAIR

PARKING BRAKE CONTROL

Exploded View

INFOID:000000005440598

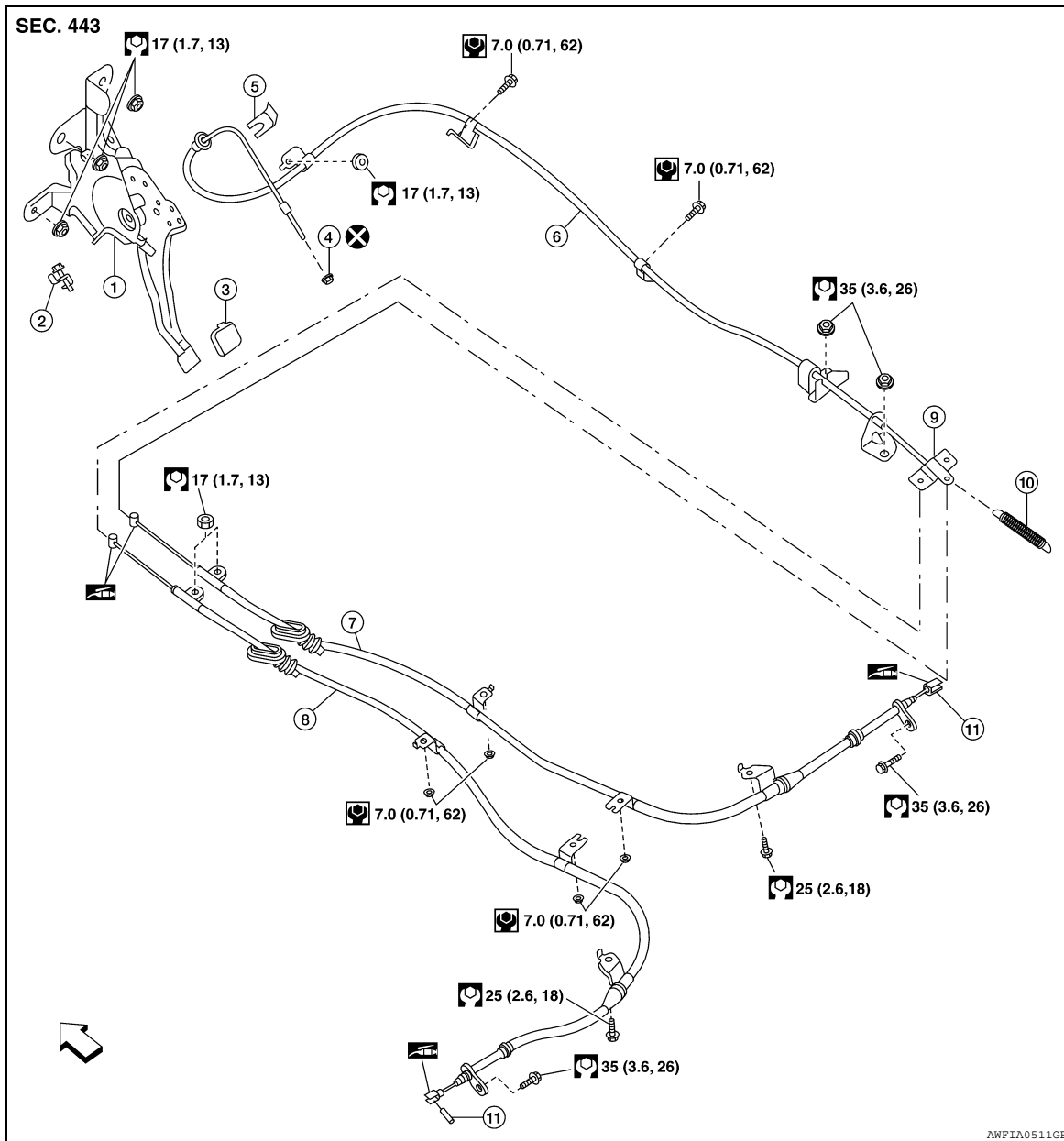

- | | | |
|----------------------------|-------------------------|----------------|
| 1. Control device assembly | 2. Parking brake switch | 3. Pedal pad |
| 4. Adjusting nut | 5. Lock plate | 6. Front cable |
| 7. Rear cable (RH) | 8. Rear cable (LH) | 9. Equalizer |
| 10. Spring | 11. Pin | ⇐ Front |

Removal and Installation

INFOID:000000005440599

REMOVAL

1. Remove rear wheel and tires. Refer to [WT-60, "Adjustment"](#).
2. Remove instrument lower cover (LH) and lower knee protector (LH). Refer to [IP-11, "Removal and Installation"](#).

PARKING BRAKE CONTROL

< ON-VEHICLE REPAIR >

3. Disconnect parking brake switch connector.
4. Remove adjusting nut and discard, then loosen front cable.
CAUTION:
Do not reuse the adjusting nut.
5. Remove control device assembly nuts and remove control device assembly.
6. Remove center console. Refer to [IP-17, "Disassembly and Assembly"](#).
7. Separate rear cables from the front cable and remove front cable.
8. Remove heat insulator of the exhaust center tube.
9. Remove parking brake shoe, and remove rear cables from toggle lever. Refer to [PB-9, "Removal and Installation"](#).
10. Remove rear cable bolts and nuts, then remove rear cables.

INSTALLATION

Installation is in the reverse order of removal.

- After installation, adjust the parking brake. Refer to [PB-4, "Adjustment"](#).

CAUTION:

Do not reuse the adjusting nut.

PARKING BRAKE SHOE

< ON-VEHICLE REPAIR >

PARKING BRAKE SHOE

Exploded View

INFOID:000000005440600

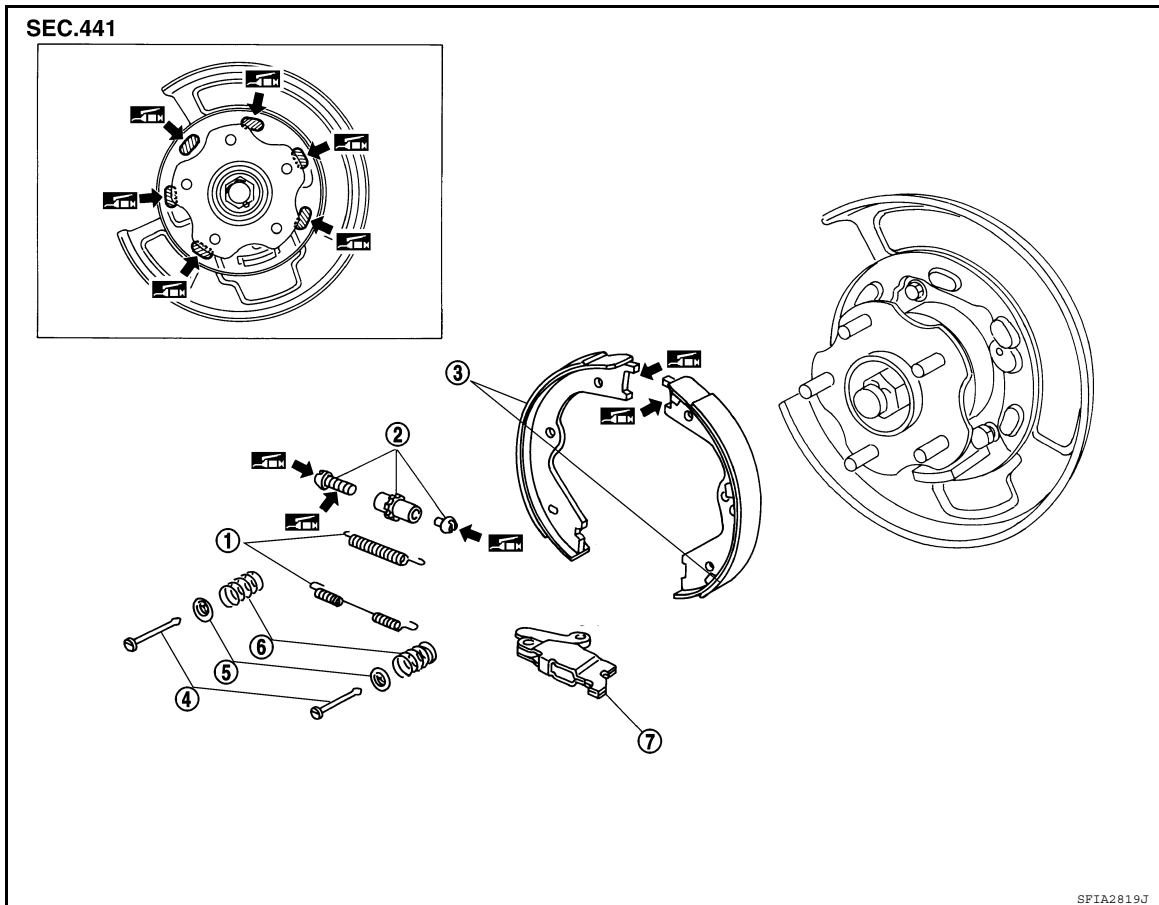

- | | | |
|--------------------|-------------|-----------------------|
| 1. Return spring | 2. Adjuster | 3. Brake shoe |
| 4. Anti-rattle pin | 5. Retainer | 6. Anti-rattle spring |
| 7. Toggle lever | | |

: PBC (Poly Butyl Cuprysil) grease or silicone-based grease

Removal and Installation

INFOID:000000005440601

WARNING:

- Clean brakes with a vacuum dust collector to minimize the hazard of air borne particles or other materials.
- Clean dust on disc rotor and back plate using a vacuum dust collector. Do not blow with compressed air.

CAUTION:

Put matching marks on both disc rotor and wheel hub when removing disc rotor.

REMOVAL

1. Remove rear wheel and tires. Refer to [WT-60, "Adjustment"](#).
2. Remove rear disc rotor with parking brake pedal in the fully released position. Refer to [BR-34, "BRAKE CALIPER ASSEMBLY : Removal and Installation"](#).
3. If disc rotor cannot be removed, remove as follows:
 - a. Secure the disc rotor in place with wheel nuts and remove adjuster hole plug.

A
B
C
D
E
PB
G
H
I
J
K
L
M
N
O
P

PARKING BRAKE SHOE

< ON-VEHICLE REPAIR >

- b. Rotate adjuster in direction (B) to retract and loosen brake shoe, using tool as shown.
4. Remove anti-rattle pins, retainers, anti-rattle springs, and return springs.
5. Remove parking brake shoes, adjuster assembly, and toggle lever.
6. Remove the back plate.

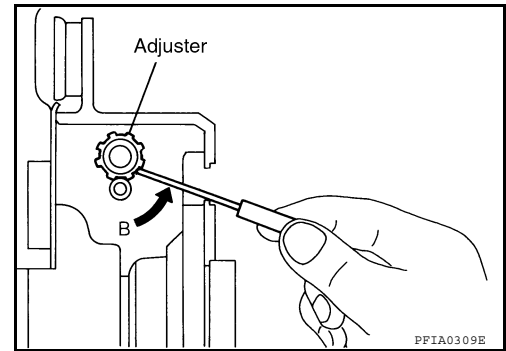

INSTALLATION

Installation is in the reverse order of removal. Note the following.

- Apply PBC (Poly Butyl Cuprysil) grease or equivalent to the specified points during assembly.
 - Assemble adjusters so that threaded part is expanded when rotating it in the direction shown.
 - Shorten adjuster by rotating it as shown.
 - Check shoe sliding surface and drum inner surface for grease. Wipe it off if it adheres on the surfaces.
 - Perform break-in operation as follows after replacing brake shoes or disc rotors, or if brakes do not function well.
1. Adjust parking brake pedal stroke to the specified amount. Refer to [PB-4, "Adjustment"](#).
 2. Perform parking brake break-in (drag run) operation by driving vehicle under the following conditions:
 - Drive the vehicle forward.
 - Maintain vehicle speed at approximately 40 km/h (25 MPH) keeping it constant in forward direction.
 - Apply the parking brake at an operating force of approximately 150-199 N (15-20 kg-f, 30-45 lb-f) with constant force.
 - Release the parking brake after approximately 10 seconds.

CAUTION:
To prevent lining from getting too hot, allow a cool off period of approximately 5 minutes after every break-in operation.
 3. Check parking brake pedal stroke of parking brake. Readjust as necessary if it is outside the standard specifications.

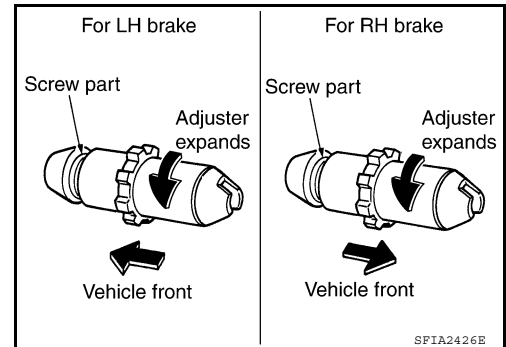

SERVICE DATA AND SPECIFICATIONS (SDS)

< SERVICE DATA AND SPECIFICATIONS (SDS)

SERVICE DATA AND SPECIFICATIONS (SDS)

SERVICE DATA AND SPECIFICATIONS (SDS)

Parking Drum Brake

INFOID:000000005440602

Brake lining	Standard thickness (new)	3.2 mm (0.126 in)
	Wear limit thickness	1.5 mm (0.059 in)
Drum (disc)	Standard inner diameter (new)	172 mm (6.77 in)
	Wear limit of inner diameter	173 mm (6.81 in)

Parking Brake Control

INFOID:000000005440603

Number of notches [under force of 196 N (20 kg-f, 44 lb-f)]	4 - 5
Number of notches when parking brake warning lamp switch comes on	1